

Goldsmith

The Pyrenees Heritage Preservation Magazine

No 141 April 2017

Lake Goldsmith Steam Preservation Association Inc

Registration No:- A0032895

Rally Grounds:-

1234 Lake Goldsmith-Carngham Road
Lake Goldsmith Vic.3373

Next Rally

GOLDSMITH AUTUMN RALLY No 109

May 6 & 7 2017



Rally Theme:- Allis-Chalmers Tractors & Machinery

+Special Event:- THE CATS ARE BACK April 29 & 30

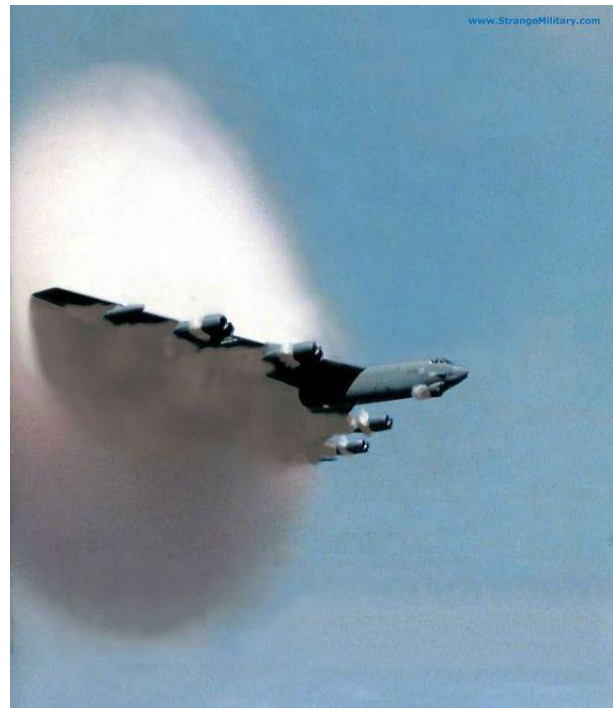

With Caterpillar and Allis Chalmers events nearly on us, and a National Rally just behind us (by the time the mail man delivers this it will be), it is difficult to remain impartial about who to picture on the cover.

The Navy have supported these events well over the years with their display of a tradition of steam and their recruiting teams have displayed current of events. The Military collectors recently displayed a fabulous variety of vehicles and equipment used by our army and our allies in conflicts of the past.

The pictures above show how to create a lot of condensate in a fraction of a second without any need to generate steam, although there will be plenty of it in the exhaust. These fabulous pictures demonstrate just how much water vapour there is in the air. It also gives us a chance to remember our Air forces and their sound deafening planes.

Editors Overview

Having got this edition underway with a bang, and added the Airforce to our cover it is time to take a closer look at what we might actually see at the 109th Lake Goldsmith Rally with its Allis Chalmers theme and the Pre rally earthmoving event organised by the Antique Caterpillar Machinery Owners Club who have just completed setting up their shed at the Northern end of the Rally grounds. It is great to have them join us.

The Theme Events that have been a successful addition to our rallies has demonstrated that there is an incredible amount and variety of machinery in Western Victoria, and it has been fascinating to see groups of machinery concentrated by make, or type, or industry on display, or in action on the arena, frequently complementing the home based equipment that form the regular attractions in our parades and demonstrations on the arena, The combination makes the display more interesting for all, and they provide an element of surprise that attracts visitors with interests in different disciplines.

The display sheds change with every rally, and each group has its own arrangements for variety. The Founders Building and John Norris Boiler House hold the bulk of the club owned assets. The 60 privately owned sheds are each mini-museums in their own right, and they are the backbone of Lake Goldsmith Rally's. The investment of the owners and the changing exhibits make ever visit different. I have yet to meet the visitor who has been able to tour every shed in a visit to a rally. These sheds have evolved over 50 years, and to my knowledge they make Lake Goldsmith Rally's a unique series of events. You just never know what you will see next.

Thank you to all of our visitors and exhibitors, and to those members whose efforts provide the attractions, and those who provide the background services so essential to our success. Ed.

Mission Statement

To foster, nurture, encourage and demonstrate technical, agricultural and life skills associated with the Industrial Era.

To provide a quality environment where these skills may be used to educate and entertain members and visitors.

To run two weekend rallies each year, and be available at convenient time for other interested groups or individuals.

To conserve and develop a heritage collection.

Find us on the net at:-www.lakegoldsmithsteamrally.org.au

Or contact us by email info@lakegoldsmithsteamrally.org.au

Or write to: The Secretary:- P.O. Box 21 Beaufort 3373

Or contact the editor:-goldsmithgazel@optusnet.com.au

To register for this "cost & obligation free" bi-monthly e-magazine "Goldsmith"

email:- goldsmithgazel@optusnet.com.au or Ph 0425 744 052

Copyright :- Our policy is to encourage redistribution, & protect our contributors, please read below!

If your organisation is a Periodic publications dedicated to the preservation of Heritage structures, machinery and skills, or a bona fide news media you may archive and republish this material free of charge without further authorisation, provided that the source of the material, that is "Goldsmith Gazette" and the "Authors name ©". if any, is acknowledged, and that the material is not used for advertising or endorsements, and that the user does not purport to licence, or assign or sell copyright to other parties. All other rights are reserved. Any authors appended ©, of work in this newsletter retain the copyright of their work and images. You may download, display, print and reproduce their material in unaltered form only for your personal use and use within your family or organisation. Apart from usages permitted under the Copyright Act 1968 such as "Fair Dealing" for the purpose of reporting, all other rights are reserved. Requests for other use of copyright material may be directed to the editor

Now it is time to take a look at the theme company whose products identify this rally.

Allis Chalmers

was an American company that formed from a series of amalgamations and acquisitions in the 19th and 20th centuries. Unlike many other mergers where manufacturers of similar products combine to reduce competition and rationalise distribution, Allis Chalmers combined companies that integrated aligned services and products which allowed them to offer their customers an enhanced service.

What was to become Allis Chalmers got under way when Edward Allis purchased a bankrupt manufacturer of Mill stones at a Sheriffs auction in Milwaukee Wisconsin in 1860. The Company expanded rapidly and by 1869 had begun producing steam engines and other steam powered equipment including pumps. By 1884 it was producing the largest centrifugal pumps in America.

Allis employed innovative experts with a background in Flour Milling, timber and steam. His sons took over the Edward P Allis Company in 1889 after he passed away,

In 1872 Thomas Chalmers founded the Fraser and Chalmers Company which became a major manufacture of mining equipment. The Chalmers had an interest in the Gates Iron Works, who had earlier employed Thomas. This company was a manufacturer of crushers and pulverisers for the quarry and cement industries.

In 1901 these 3 companies merged to form the Allis Chalmers Company, and they acquired the interests of a 4th Company, the Dickson Manufacturing Company who manufactured air compressors and blowers, Internal Combustion and Steam engines and Railway Locomotives. The Locomotive business was separated and became the American Locomotive Company ALCO, a mainstay of Steam Locomotive manufacture. The newly formed Allis Chalmers was now a supplier and constructor of major Capital Works for Industrial Corporations in the Steel, mining and production business.

In 1903 Allis Chalmers acquired the Bullock Electric Company and added steam turbine manufacture to its product line.

In 1912 Allis Chalmers was in financial trouble. It was renamed the Allice-Chalmers Manufacturing Company and Otto Falk was put in charge to return its fortunes, Falk pushed for expanded products and markets, and his venture into mechanised agriculture led to the manufacture of the orange tractors and construction machinery that are so popular with collectors and visitors at Heritage machinery Rallies.

The first Allice Chalmers Tractors, produced between 1914 and 1919 were the 6-12,

10-15, and 15-30.

The model 6-12 is (shown on the left) had 6 drawbar horse power and 12 on the belt. It weighed 2500 lbs.

The motor was a 4 cylinder 138 CID petrol engine made by LeRoi. It had 1F & 1R gears and cost about \$800.

The rear Sulky wheel was removed

and replaced by an implement. About 1470 were built between 1918 and 1926

See www.steel-wheels.net/allis.html for more info on these early models.

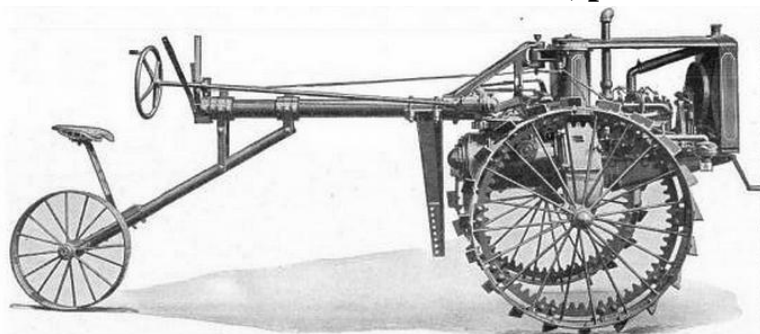



The first conventionally styled 4 wheel tractor produced by Allis Chalmers was the 15-30 introduced in 1918. This tractor used Allis Chalmers own OHV petrol engine which had a 4.75” bore and 6.5” stroke and ran at 830 RPM.

This tractor evolved into the 18-30,20-35 and 25-40 and remained in production until 1936, when it was replaced by the model A.

In 1921 a small brother to the 18-30 was introduced as the model L12/20 which evolved into the L 15/25 and remained in production until 1927.

In 1929 the United Model U was introduced. When Ford stopped manufacturing the Fordson Tractor in the United

States, a group of manufactures who sold attachments for the Fordson were left without a tractor. They jointly contracted Allis Chalmers to produce a suitable replacement, to be sold by the, United Tractor and Equipment Corporation.

About 19000 of these tractors were built and they used motors manufactured by Continental, Waukesha and Allis Chalmers which produced about 20 drawbar horsepower and 30 on the belt. The United name was dropped in 1931, and the tractor continued in production until 1948 as the Model U.

Also in 1929 Allis Chalmers started painting their Tractors Prussian Orange, which was the nearest colour to the Californian Poppy which inspired the change. This colour gave the tractors a high visibility, and soon other tractor manufacturers followed with bright colours of their own.

In 1932 Allis Chalmers and Firestone developed a pneumatic rubber tyre for tractors as an alternative to the all steel wheels that were in use at the time.

The gains in Traction and Fuel economy range from 10 to 20% and soon pneumatic tyres were the normal arrangement. Comfort, reduced driver fatigue, and the ability to drive on public roads were also major advantages of pneumatics. The downside was an increase in cost.

The higher speeds available on rubber led to speed trials, and in 1933 Barney Oldfield ran at an average speed of 64.2mph in a high geared model U on Firestone tyres, and later in 1935 Ab Jenkins upped this to 68mph at Bonneville Salt Flats.





The earlier attempt was on Harvey Firestone's farm in Ohio. Barney Oldfield is on the



left below and Ab Jenkins is on the right. The rear tyre tread is a Chevron shaped V.

Early attempts to use truck tyres failed when the tyres spun on the rim due to the high torque tractor drive. Experiments with Firestones 48(24) * 12 Aeroplane tyres had more success. The production tyres were 11.25*24

The Model U replaced the Continental 4 with Allis Chalmers own 4 cyl. OHV unit in 1932, and the model U continued in production until 1948.

The high cost of rubber was a major factor in the high tyre price. To offset this, the Model WC row crop tractor was introduced in 1933. This was the first tractor produced with Pneumatic tyres as standard, and steel as an option. It was also the first rubber tyred tractor tested at Nebraska.

To avoid large diameter expensive tyres the final drive used drop gears to lower the axle centre line and still maintain the high clearance needed for a row crop tractor, The



Tractor used a steel channel side frame to avoid heavy castings, and a power take-off was fitted to power towed machinery. This tractor remained in production until 1948, by which time 178 000 had been produced making it the highest selling tractor made by Allis Chalmers. It could use petrol, kerosene or alcohol fuels. From 1939 electric start and lights were made standard. In 1938 the WC was the first tractor to use stylists to design the sheet metal when a larger radiator cowl was added, and the controls were

rearranged.

Staying with the small tyre idea Allis Chalmers introduced its second row crop tractor, the Model B in 1937. This tractor was aimed at small farms, who in the main still relied on horses. There were about 4 million farms under 100 acres in the US at the time, so there was a good potential market for the "B", and various variants which were produced before production ceased in 1957, when about 121 000 had been produced at West Allis in Wisconsin and Southampton in the UK.



The rear drive tyres were 9.00*24, and the fronts, were 4.00*15. The tractor originally produced 16hp at the belt and 13 at the drawbar which was enough for one 16" plough. From 1950 the Belt Hp went up to 22 and the drawbar 19 hp.

An innovation in the layout of the B was the introduction of a patented Torque Tube to connect the motor and transmission and house the drive shaft. This arrangement saved weight and improved visibility of the cultivator tools below.

The B could be supplied with a high clearance fixed front axle or an adjustable one, as can be seen on the picture downloaded from the excellent Tractor Data website.

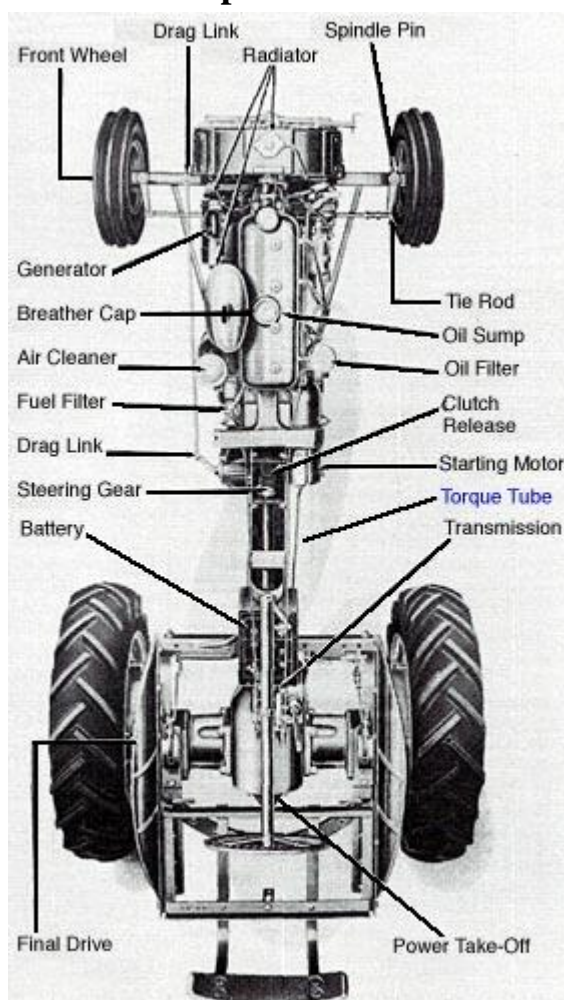

Allis-Chalmers Model "B" with its covers off showing all major parts, including the new Torque Tube allowing better visibility.



A centre mounted dual is seen on the tractor (left) which is fitted with the optional steel wheels. From



1940 to 1950 the model C had the same hp as the later B. It had dual front wheel as standard.

In 1948 the WD40 replaced the similar WC and stayed in production until 1953. This model introduced the double clutch system which allowed the PTO to run independent of the drive. It was superseded by the WD 45 with power steering and, later, when Allis Chalmers acquired Buda, an optional 6 cylinder Diesel engine. Of the 90 000 produced about 6500 were diesel powered.

This model was equipped with a new snap coupler, similar to a ring feeder, which allowed the attachments to be connected while the driver was still seated. It was some time before a 3PL system caught up.

In 1948 the 4 cylinder 9hp Model G was introduced. This rear mounted engine layout gave the driver an excellent view of the ground in front of him which gave excellent control.

About 30 000 of these machines were built before production ceased in 1955.



Another interesting feature of Allis Chalmers is their power shift rear track adjustment. The tyre rim has 4 cam rails attached at the quarter points. With the clamps loosened, the rim & tyre are rotated and backward or forward to change the track. The adjustable axle or dual front wheel was used in combination with these rowcrop tractors.

Allis Chalmers had considered using the Fergusons 3 point linkage but it did not come to fruition. It developed its own system which was designed to suit their own line of attachments, as did many other makers.

The Ferguson patents expired in 1960 and eventually an international standard for tractor hitches came into effect (ISO 730-1)

In the 1950's Allis Chalmers gradually introduced improved models.

The D15 30hp rowcrop was introduced in 1957 and 7000 were produced before it was superseded by the D17 in 1960, which had a small power increase. The 24hp D10 and wider track D12 were introduced in 1959. The D 10 (picture on right), D12 and larger 45hp D17 ceased production in 1968 when the demand for diesel engines made them uneconomic.



A D19 58 dbhp was produced from 1961 to 1964 and the D21 with 63 draw bar hp was made from 1963 to 1965.



The D19 above left and the D21 were the largest of the D series. The 21 was the first Allis Chalmers tractor to have a 100hp engine with 93 at the drawbar. The engine was a 7 litre 6 cylinder Diesel. It was the largest of the D Series Tractors. The D19 was available with petrol, LP gas, or Diesel.

The D series was the last of the alphabetic series of Tractors. The Numeric Series models started with the 190 which superseded the D19 in 1964.

The models ranged from the smallest 170 (below left) available in Petrol or Diesel to the largest 220 (pictured on right) which was a turbo charged 6 cyl. Diesel.



This brings us to the 1970's and a fair place to end the tractors for a heritage show.

For those interested there is a lot of information on the net. www.tractordata.com has a lot of technical data and www.livinghistoryfarm.org & www.wikipedia.org are good places to start. If you are looking for parts www.yesterdaytractors.com is also a start.

Allis Chalmers also manufactured Graders and tracked tractors, and during WW2 they also produced specialised machines for the military. For this edition we will take a look at the graders and the tracked tractors and Dozers. Allis Chalmers also produced an enormous range of farm and industrial attachments, but these will not be covered

here. This does not mean that they will not be at the rally. Implements, particularly on rowcrop tractors can make a really impressive display, and provide an insight into the variety of gear available and the tasks that they were used for.

Allis Chalmers Graders

Allis Chalmers first association with Graders was in 1920 when the Russel Grader Manufacturing Company introduced its “Motor Partrol” grader which was made by attaching a frame around an Allis Chalmers tractor . Later Russel was acquired by Caterpillar. In 1930 Allice Chalmers started manufacturing its own graders and in 1932 it acquired the Ryan Manufacturing Company who manufactured graders.



The Allis Chalmers Graders above are taken From the Tutt Bryant website. Tutt Bryant were the Allis Chalmers agents in Australia from 1939. Later Allis Chalmers operated in Australia under their own name. I am not sure about the towed Grader on the left, the on the right is one of the various Model D which were introduced in the 1940's and continued into the 1950's . The bent tubular frame seems to be a common feature of this series.

The W series tractor grader (right) was produced with a hand controlled belie board, which certainly made for a compact machine.

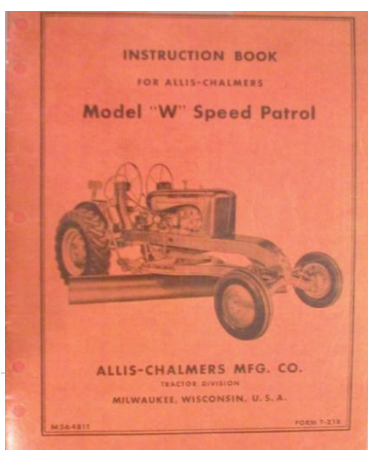

For larger models, the tractor frame was extended forward offering better control for their Speed Patrol series of graders. Manual control of the blade was retained. These machines

were virtually a combination of a tractor and a towed grader, which halved the number of operators, required and made for a much more versatile grader.



These model W Speed Patrols were an attractive machine, as can be seen above.



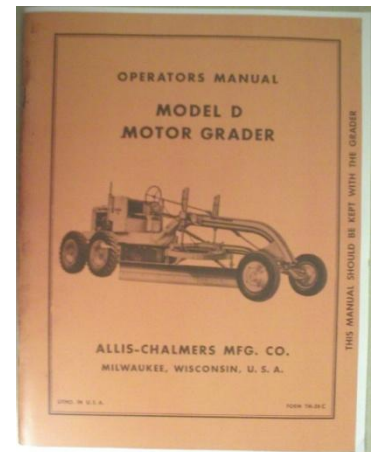

The tubular frame gave way to a fabricated frame as can be seen on the picture on the right which is a Tutt Bryant demonstration downloaded from their website. In 1961 Allis

And they could be fitted with hydraulics to make life easier for the plant operator.

The distinctive tubular frame of the early towed models followed into the D and DD models which lasted into the 1950's, by which time the motor had moved to the rear and hydraulics and a cab made life more comfortable for the operator.



Chalmers Australia Pty Ltd was formed in 1961 and operated until 1973.



By the late 1950's the conventional looking M model arrived with 100hp

There is not a lot of information on A-C graders on the net but for anyone with an interest there is a lot more than the few pictures that have been included here. Now we will leave the Graders and move on to the Crawler tractors.

Crawler Tractors

Allis Chalmers acquired the Monarch Tractor Company in 1928 . The company started in 1913 in Wisconsin USA. (There was a similarly named company in the UK)



Its first products were the Lightfoot 10-6 and the Neverslip 20-12. 1919 saw the Neverslip 30-18 added to its small tractor range. The picture at the left is an 18-30. A feature of these tractors was the use of a steering wheel to operate the Brake and Clutch steering.

This continued until the 1930's

when Allis Chalmers adopted lever control. During the 1920's heavier machines were developed and the 6 and 10 Ton models were introduced, and soon these models became the model 50 (Photo on right from www.steelwheels.net/monarch.html) and





model 75, which in turn became the model H and model F respectively. These models were followed by the popular Allis Chalmers model M, K & L and in 1937 the model S. The early models retained the steering wheel, and this petrol/oil 4 cyl. 40hp K (below) was characterised by dual unsilenced exhausts.

By the late 1930's Allis Chalmers offered the K as a KO (O for oil). This model used a diesel style injector and pump system to allow it to use diesel or other cheap oil for fuel. The Injector pump (see below) was mounted on the opposite side of the engine to the magneto (see above). As this was a spark ignition engine it, unlike a true high compression diesel had to have the correct fuel air



mixture to ignite, which mean that the fuel had to be controlled to match manifold pressure. To achieve this there was a vacuum actuated device on the end of the injector pump which controlled the injector pump displacement to match what would have been supplied by a carburettor.

Similarly the Governor was connected to a carburettor style throttle rather than the injector pump as it would have done in a diesel. The compression ratio was low, similar to spark ignition engines of the day, and hand cranking was the standard starter. (Electric starter motors and other electrics were an option)

The parts book cover shows the later lever steered model, KO and the drawing below shows depressed piston crown, including a nick to clear the injector at TDC. The extended

**PARTS BOOK
FOR
ALLIS-CHALMERS
MODEL
"KO" TRACTOR**

This book applies to TRACTORS
SERIAL K05200 and ABOVE

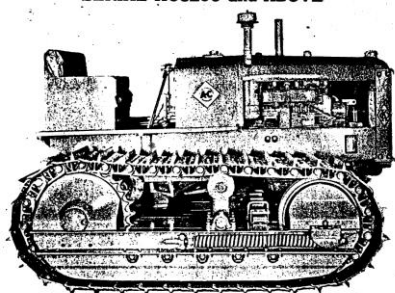

Allis-Chalmers Mfg. Co.
TRACTOR DIVISION
MILWAUKEE, WISCONSIN
U. S. A.

FORM No. TPL80B

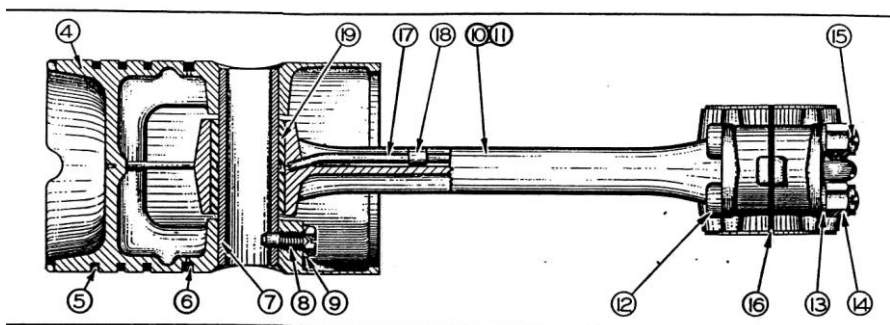

PLATE 3 - PISTON AND CONNECTING ROD

piston wall would run hot to assist vaporising the atomised fuel from the injector.

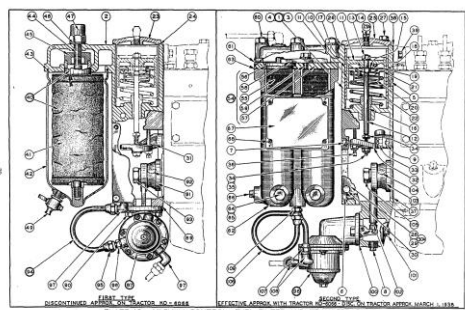

PLATE 16 - VACUUM CONTROL, FUEL FILTER AND TRANSFER PUMP

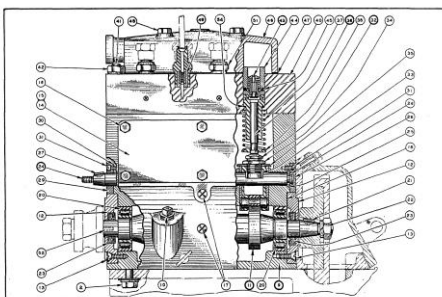

PLATE 15 - INJECTION PUMP

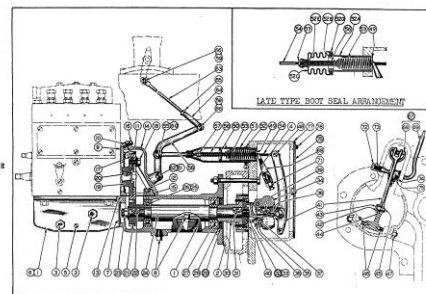

PLATE 14 - GOVERNOR AND INJECTION PUMP DRIVE

The 3 drawings above show, from the left, the vacuum control unit which controls the displaced fuel by actuating the displacement control shaft (24) on the centre drawing. The Fuel feed pump is driven from an eccentric (103) on the injector pump camshaft (11) driven from the governor on the drawing on the right, via the gears.

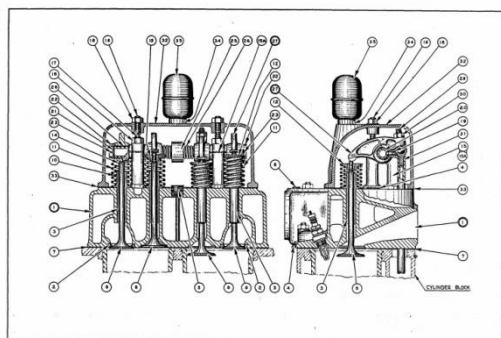
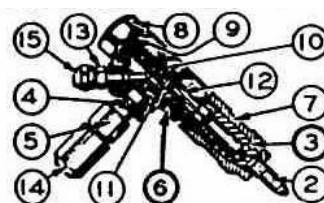

PLATE 12 - CYLINDER HEAD

The drawing on the left shows the Cylinder head arrangement and the spark plug with the extended electrode can be seen, the spark plug is opposite the injector nozzle (not shown) and both are in the piston crown at TDC. The Injector is shown on the right.



These engines are frequently referred to as Diesels, which is not correct as they do not use compression ignition. They use injectors to allow cheap oil fuels to be used in a spark ignition engine. Diesel oil was almost a waste product in the 1930's, (its low price also made Diesel locomotives an economic alternative to steam at the time). The use of spark ignition kept the weight of engines down, and they were the first direct injection spark ignited engines to be used in trucks and buses until true diesels had developed as an effective alternative to petrol.

They were also referred to as Semi Diesels, presumably because they used a conventional Diesel injector and pump with an altered delivery control.

The engines were invented in Sweden in 1925 by Jonas Hesselman, Scania used them until the mid 1930's, and Volvo used them until 1947.

Allis Chalmers offered them in their tractors until they switched to using General Motors 71 series 2 stroke Diesels.

Waukesha offered them in various engines, and they have been used by other makers.

The upside was that they could use cheap fuel, and they could run on Kerosene and petrol with some gain in economy over a carburettor.

The downside was that they were prone to fouling and sooting up plugs (this may have been another reason for the long electrode plugs) when cold. They would have trouble meeting modern exhaust standards.

They were generally started on petrol and switched to oil when they reached operation temperature. They were switched back to petrol to prime the injector pump and flush the heavy fuel from the system ready for the next cold start.

Hesselman was also involved with Diesel engine development at Atlas Copco and he was the first to develop a reversible diesel which made it a practical for use in ships.

Now back to the Crawlers.

The Model K was made from 1929 to 1943. It had a 510CID 4 cylinder engine with a 5" bore and 6.5" stroke; it produced 55hp at 1050rpm. It weighed 5.25 tons. About 9500 were built.

The largest was the model L which was produced from 1931 to 1942 and about 3500 were built. It was also offered with a Hesselman Diesel option. It used an 844 CID 6 cylinder engine and produced 105hp at 1050rpm at the belt. It weighed in at 10 tons.

The Alphabetic series was replaced by the HD series. In 1940 the HD7W was introduced using a GM 3-71 blower 2 stroke engine.

The HD10W (W for wide Track) with a 4-71 engine was used widely by the military who used over 1700 of them. Similar tractors were made by Caterpillar and International Harvester and were collectively known as M1 heavy tractors.

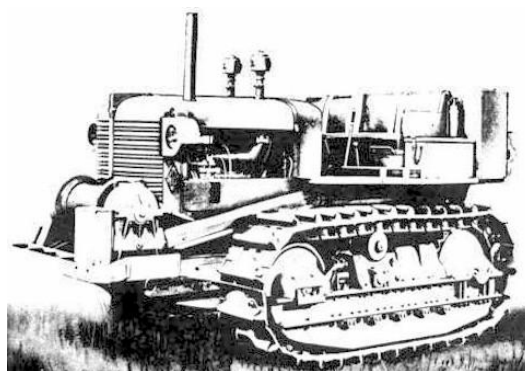
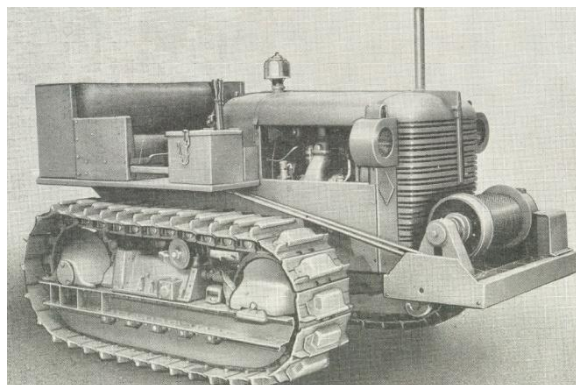

The HD7W is shown on the left and the HD10W is on the right. Both are shown with front mounted winches.

Allis Chalmers reached an arrangement with GM to use their Diesel engines. This agreement lasted until GM acquired Euclid and became a competitor. Allis Chalmers brought the Buda Engine Company in 1953 and the Buda-Lanova engines became Allis Chalmers Diesels.

Allis Chalmers was very involved in many aspects of War production from 1940 /45.



In 1944/45 they produced over 1200 of these M6 Artillery Tractors to tow 8" & 10" howitzers. They had a crew of 11, weighed over 34 Tons and were powered by two 13.4L OHV 6 Cyl Waukesha petrol engines that produced 190HP each at 2100rpm . This impressive combination can be seen at the Liberty Park Museum at Overloon in the Netherlands.



Using just 1 of the above motors the M4 High Speed Tractor could get along at 35 mph. It went into service in 1943 and stayed there until 1960. It was used to tow the 155mm long tom and others. It was based on the M2 tank components, and was equipped with air and electric brakes to match the towed gun or trailer. Over 5500 were built and many were converted to peace time applications after WW2.

On a smaller scale A-C built 291 of these M7 Snow Tractors (based on a jeep motor and transmission and A-C tractor parts), and, 1050 M19 timber bodied trailers for the

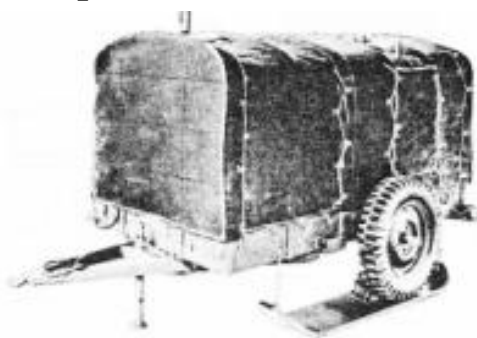

US Army Airforce. The tractor and trailer wheels could be fitted with skis. The trailer had a rear pintle hitch for a second trailer. The trailer was fitted with a heater and 2 stretchers.

After WW2 Allis Chalmers returned to peacetime production and expanded the range of their HD series of tracked tractors, which continued until the mid 1970's. The smallest was the 36hp HD 3 which ran from 1960 to 1968 and the largest was the 225hp HD21 which ran from 1953 to 1965.



NOW... Front-End Shovels for ALL 4 New ALLIS-CHALMERS Tractors

14 Interchangeable Attachments

Standard Buckets
Light Materials Buckets
Heavy-Duty Buckets
Rock Forks
Bulldozer Blades
Plus other attachments for some models

1-Yd. HD-5G
Drawbar hp.: 40.26
Dumping Height*: 9 ft. 1/4 in.
Total Weight: 16,200 lb.

2-Yd. HD-9G
Drawbar hp.: 70
Dumping Height*: 11 ft. 4 1/2 in.
Total Weight: 29,800 lb.

3-Yd. HD-15G
Drawbar hp.: 102
Dumping Height*: 12 ft. 8 in.
Total Weight: 40,000 lb.

4-Yd. HD-20G
Hydraulic Torque Converter Drive—175 net engine hp.
Dumping Height*: 13 ft. 5 in.
Total Weight: 61,600 lb.
*Height of bucket hinge

Standard Buckets up to 4 cu. yd.
(light materials buckets up to 7 cu. yd.)

Introducing a New Era of Tractor Usefulness . . .

These new Tractomotive shovels on the larger size Allis-Chalmers tractors now bring you the same wide utility, the same outstanding performing ability as the popular HD-5G—the Tracto-Shovel that revolutionized excavating and material handling.

The Newest, Finest Tractor Line on Earth . . .

The new Allis-Chalmers tractors are not just refinements of existing models . . . they are new from the ground up . . . without compromise anywhere in design or materials. Back of their design are your own ideas and those of your operators and mechanics. These are combined with the vast experience of Allis-Chalmers to set new standards of Performance, Durability, Simplified Servicing, Ease of Operation.

ALLIS-CHALMERS
TRACTOR DIVISION • MILWAUKEE 1, U. S. A.
Originator of the Torque Converter Tractor

In the mid seventy's A-C formed an alliance with Fiat for expanded construction machinery sales in Europe, but this arrangement ended in 1985 when Fiat brought A-C's 35% share and renamed the company Fiat Allis.

To compete with Kubota, Allis Chalmers imported Hinomoto tractors and rebadged them as A-C.

In 1985 A-C's farm business was sold to Deutz AG of Germany who renamed the company Deutz-Allis and the Persian Orange colour changed to green. In 1990 Deutz-Allis was sold to the parent company and renamed AGCO who sold the tractors as AGCO-Allis and returned the colour to Persian Orange. In 2010 The AGCO Allis brand was dropped.

The unsold manufacturing plants retained by A-C were sold off and in 1998 the remaining service industries were renamed Alice Chalmers Energy, which operated in the Oil and Gas industries and is based in Texas. In 2011 it became part of Archer.



In 2008 Briggs and Stratton released Allis Chalmers mowers.

The foregoing pages are a series of cherry picked items that might be of interest. You might even see some of them in May at the 109th Lake Goldsmith Rally.

EARTH MOVING SPECIAL



As a special event this year The Antique Caterpillars Machinery Owners Club is staging an earthmoving weekend at the Lake Goldsmith Rally Ground on the weekend before the 109th Rally.

The Nationally Rally at Hamilton is on the weekend after Easter and a lot of Caterpillar machinery that will there will also be at the 109th Lake Goldsmith Rally a fortnight later. The weekend in between offered an ideal opportunity to put this gear to work and have an earthworks display, for the Caterpillars and anything else that can move some dirt around,
ALL BRANDS WELCOME.

The Caterpillar group have recently completed their Shed at the Lake Goldsmith Rally Grounds, It is on the North Boundary of the Rally Grounds, right next to the Northern earthwork display area.

It is great that they have taken up a presence on site, “CAT’s” are universally popular.

There have been Caterpillars at Goldsmith for as long as I can remember, but they have never been there in the numbers that turned up to the Caterpillar Rally a few years back when there were over 40 vintage Caterpillars on site and the centre of the parade ground looked as if it was turned upside down, a grand parade with a grand excavation.

If you like watching excavation action this is a day for you.



There are times when everyone needs a push.



This one could help.



16th NHMA National Rally
 Hosted by
 Hamilton Pastoral Museum Inc
 Bringing Back The Memories

21st, 22nd & 23rd April 2017

Hamilton Harness Racing Club

Contact Information for Host Club
 Email: hamiltonpastoralmuseum@live.com
 Web: www.hamiltonpastoralmuseum.com.au

Hamilton Pastoral Museum Inc.
 Cnr Hillier Lane & Ballarat Rd.
 P.O. Box 227
 HAMILTON, VIC. 3300. Ph. 03 9571 1995

LAKE GOLDSMITH
 in conjunction with
ANTIQUE CATERPILLAR MACHINERY OWNERS CLUB
 are holding their inaugural

**EARTHMOVING
 DISPLAY DAY**

**29TH - 30TH
 APRIL, 2017**
 1 WEEK PRIOR TO THE
 109th STEAM RALLY

All makes welcome.
 Featuring cable
 operated scoops,
 face shovels, back
 actors & dragline,
 90 ton Ruston
 steam shovel,
 Bucyrus rail
 mounted steam
 shovel and much more.

**9AM - 5PM
 BOTH DAYS**

ADMISSION: Adults \$10.00 Children aged 5-16 \$5.00 Exhibitors and Children under 5 free.

Unpowered camping for exhibitors only. Catering on site.

For more information contact:
 Mark 0407 819 340 or
 Glen 0409 955 936
www.lakegoldsmithsteamrally.org.au
LAKE GOLDSMITH STEAM PRESERVATION INC.
 #00328985



The National Rally at Hamilton will be over by the time the print copy of this edition gets out, but the email and Web version might make it.

The Steam and IC earth moving show at Lake Goldsmith is on the next week end as you can see from the flyer above right, and the Allis Chalmers themed Lake Goldsmith Rally will follow a week later.

The March MSTEC Steamfest Rally at the Australian Steam Centre in Scoresby was a lively event this year with great weather and a good turnout of visitors.



Square bales were made in this hand fed, belt driven Mitchell & Co. hay press,



MSTEC STEAMFEST 2017



There was a lot of action on the hard pack, and the Ransomes Rapier went for a walk and was open for a walk through inspection by visitors. The steam gear ranged from Road Locomotives to a White Steam Car, complete with a steam circuit diagram.

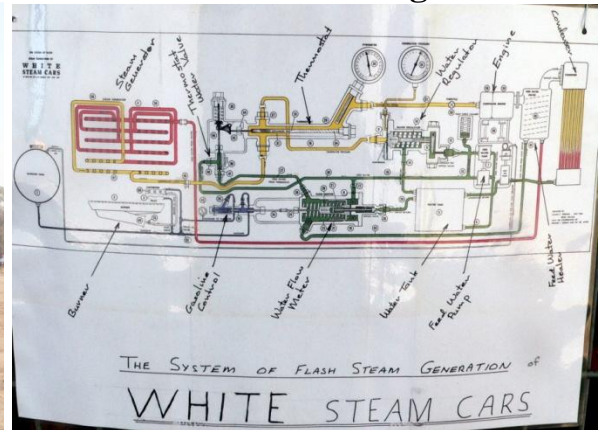

Unlike most other steam traction, the White condenses exhaust steam and returns it to a tank for reuse. The reduced weight of water and higher feed temperature save fuel and extend range of the vehicle on the road. The centre picture is a “spare” White engine from a later model. The acetylene headlights are a quaint feature from an era when cars were almost free of electric accessories. The opposite is true of this early 2 valve radio which was part of the display in the clubhouse. An early crystal set (cont)



was also on display along with many other early radios and models of various machines

This commercial crystal set complete with its hand operated “cats whisker” is a neat device when compared to the home made models of my youth. The Cats Whisker was later replaced by diodes, and amplifying radios eventually led to the disappearance of the array of long ariels that graced most backyards in the early days of radio.

The radio display is always popular, and it covers the period when vacuum valves were king and the start of the transistor portables. The clubhouse is always worth a visit, the display changes every year.



Fords were on display, although most had gone before the camera caught them, the early 50's Customline was caught at the gate, but the Bren Gun Carrier built by Ford

at their factory in Sydney in 1942 was well anchored. This machine had been cut down and fitted with a forward mounted c1948 Nash engine mounted forward for rural or industrial use. Fortunately the Ford rear truck axle and gearbox were retained, and only minimal armour plate was removed. There will be a hunt for a 95hp side valve Ford V8 Mercury Engine and radiator that were originally fitted, and the steering gear and front compartment fittings and controls will be next.? Can anyone help.



The Short pitch (1.75") tracks have 176 links on each side and the axle is 1938 Ford, The 35 tooth ring sprocket is bolted to a modified wheel centre. These Local Pattern Carriers MG were different to the Canadian and British models, to suit local supply's.



Warwick Bryce's Stuart Tank is back on its home ground, and Rob Jones new Chev is on the way to a new life. This Essex is an excellent example as is this 1950's van.



The 2017 Steamfest at Scoresby, about 20KM East of Melbourne was a great success. For those who missed it, your chance will come next March for Steamfest 2018.



There are some parking spaces that you just can't back out of.

THE LAKE GOLDSMITH AUTUMN RALLY

May 6 and 7 is the last of 4 in a row in the West, so it will be the Grand Finale for the 2017 Autumn Rally Season.

The Displays will be back from the National Rally to join the home based fleet, the Caterpillars and other gear from the Earthmoving Workout will be on hand to add to the resident and visiting Allis Chalmers, and the sheds and display areas will be open.

All up there should be a good variety, and a lot of it. Enjoy the weekend.

LAKE GOLDSMITH 109TH Steam & VINTAGE RALLY

**MAY 6th &
7th, 2017**

Additional to our 65 display sheds, steam & oil engines, 90 ton Ruston steam shovel, Bucyrus rail mounted steam shovel, blacksmith & radio controlled model boats. Trucks, tractors, cars, motorcycles, threshing & chaffcutting. Dragline & steam powered sawmill demos. Grand Parades daily. Attractions for ladies and children. Stalls, crafts & food available. Camping for exhibitors only (free, non-powered).

ADMISSION PRICE:

Adults \$15.00 • Children aged 5-16 \$5.00 • Exhibitors and Children under 5 free.

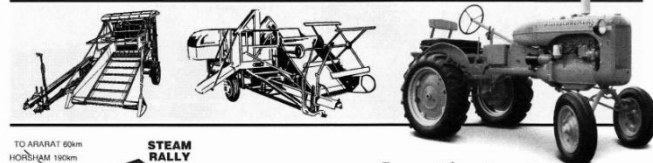

For more information contact:
PO Box 21 Beaufort 3373
Ph. Trevor 0407 539 041 or Graham (03) 9723 3310
www.lakegoldsmithsteamrally.org.au
LAKE GOLDSMITH STEAM PRESERVATION INC.
A0032898S

BEAUFORT HISTORICAL SOCIETY APEX
BEAUFORT MEN'S SHED PYRENEES HISTORIC VEHICLE
ASSOCIATION & BEAUFORT PROGRESS ASSOCIATION

Present

BACK TO BEAUFORT

Celebrating Beaufort

*Historic Walking Tours, Historic Homestead Tours,
Beaufort School Reunion, Historical Vehicle Exhibition, Bric a Brac
Market, Food trucks, School House Blues Music @ Sparrows Café*

Saturday 27th May 2017
10am to 8pm

Tickets available online for tours, school house blue's and reunion
Gold Coin donation at Gate on day to market

At

TThe Old Beaufort Primary School
Neill St, (Western Highway) Beaufort

Enquiries - 0414 082 754 www.visitbeaufort.org

BACK TO BEAUFORT

Beaufort will be hosting a Back to Beaufort day on May 27. As part of this day Ron and Linda Harris will be opening the Goldsmith Beaufort Goods shed, which is now getting well filled with exhibits. On the day, the Pyrenees Historic Vehicle Association will be assembling outside the Goods Shed and opposite the Men's Shed. This is a large club which is based in Avoca and has an excellent turnout on their run days. You can look forward to a colourful turn and a wide spread of historic vehicles.

The walking trail to camp hill will be open to the public, there are some fabulous views of Beaufort and the Lake Goldsmith operated Railway Goods Shed.

All up May 2017 will be a good Month in Beaufort, with the 109th Rally at the Rally Grounds at Lake Goldsmith and the Back to Beaufort Day a fortnight later.

The President, Committee and LGSPA Members hope that the visitors to these events enjoy their time in the picturesque Pyrenees Shire in Western Victoria in May 2017. Ed